

Ref. : RF 1100S.pas

Rev. : Initial

Date : 30/04/2013

Page : 1/1

BRASS FLOAT VALVE

RF 1100S



Tecofi
VALVE DESIGNER - FRANCE

APPLICATION

Fluid section.
Measure, control, gauge.

GENERAL CHARACTERISTICS

Ball valve with double toggles.
Brass body, copper float or ajustable PVC.
Round arm for connection from DN12 to DN50.
Flat arm from DN65 to DN80.

CONSTRUCTION

5	1	Lever	Brass
4	1	Nut	Brass
3	1	Seat	NBR
2	1	Float	Copper
1	1	Body	Brass
Rep.	Nb.	Description	Material

DIMENSIONS

DN		A	ØC	B	L	D	Working pressure PSmax (bar)	Weight Float (kg)	Weight Valve (kg)
mm	inch								
12	3/8"	245	90	280	34	-	8.94	0.092	0.173
15	1/2"	270	110	280	35	-	11.38	0.144	0.196
20	3/4"	280	130	360	38	-	10.79	0.186	0.324
25	1"	310	150	380	40	-	10.17	0.246	0.501
32	1" 1/4	450	180	460	50	-	10.59	0.423	1.020
40	1" 1/2	500	200	490	55	-	11.11	0.500	1.400
50	2"	600	230	620	70	-	11.87	0.605	2.460
65	2" 1/2	475	280	625	80	550	10.50	1.017	3.900
80	3"	580	300	780	100	675	10.00	1.290	6.780

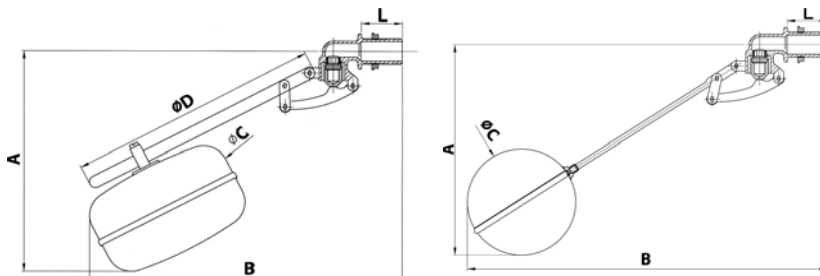
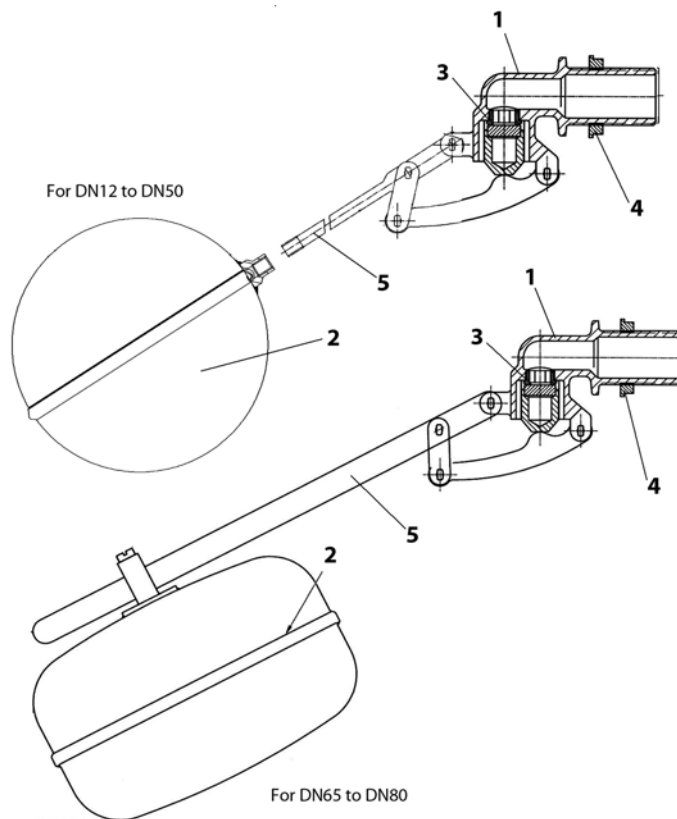

WORKING CONDITIONS

Maximum temperature : + 80°C.

Pressure test according to standards
EN 12266-1, DIN 3230, BS 5154 and ISO 5208.

STANDARDS

BSP threaded according to standard ISO 228-1.

PRESSURE FLOW	DN								
	3/8"	1/2"	3/4"	1"	1"1/4	1"1/2	2"	2"1/2	3"
Pressure (bar)	3	3	3	3	3	3	3	3	3
Flow (l/min)	64	114	257	457	714	1029	1828	2273	2809
Pressure (bar)	4	4	4	4	4	4	4	4	4
Flow (l/min)	74	132	297	528	824	1187	2110	2624	3244
Pressure (bar)	5	5	5	5	5	5	5	5	5
Flow (l/min)	83	147	332	590	922	1328	2360	2934	3627
Pressure (bar)	6	6	6	6	6	6	6	6	6
Flow (l/min)	91	162	364	647	1010	1455	2586	3214	3973
Pressure (bar)	7	7	7	7	7	7	7	7	7
Flow (l/min)	98	174	393	698	1091	1571	2792	3472	4292
Pressure (bar)	8	8	8	8	8	8	8	8	8
Flow (l/min)	105	186	420	747	1166	1679	2985	3712	4588
Pressure (bar)	9	9	9	9	9	9	9	9	9
Flow (l/min)	111	189	445	791	1237	1781	3165	3937	4866
Pressure (bar)	10	10	10	10	10	10	10	10	10
Flow (l/min)	117	208	469	835	1304	1878	3338	4150	5130

TECOFI France - 83, Rue Marcel Mérieux 69960 Corbas - FRANCE
Tél. +33 (0) 4 72 79 05 79 - Fax +33 (0) 4 78 90 19 19 / +33 (0) 4 72 79 05 70
Adresses e-mail : sales@tecofi.fr ; tecofi@tecofi.fr / Site web : www.tecofi.fr